

MODEL IDENTIFICATION

Model 3 2 A

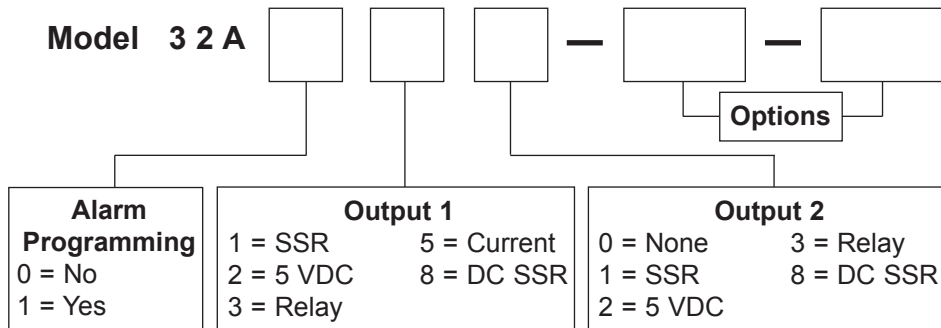

Options:

- 992 RS-485 Serial Communications. Allows remote computer to read and write all control parameters.
- 9502 12 - 24 VDC/VAC 50-400Hz power supply (control operates on low voltage equipment).
- Note:** Only Option 9502 may be combined with another option. No other options may be combined.